

# **Microwave and radar engineering**

**By**

**Suresh rani**

**Lecturer ECE**

**GP JHAJJAR**

# Microwave Communication System

**Microwave transmission** is the transmission of information by microwave radio waves.

In the electromagnetic spectrum, waves within the frequencies 1GHz to 300GHz are called microwaves.

## Features of Microwaves

- Microwaves travel in straight lines, and so the transmitter and receiver stations should be accurately aligned to each other.
- Microwave propagation is line – of – sight propagation. So, towers hoisting the stations should be placed so that the curvature of the earth or any other obstacle does not interfere with the communication.
- Since it is unidirectional, it allows multiple receivers in a row to receive the signals without interference.
- Microwaves do not pass through buildings. So, indoor receivers cannot be used effectively.
- Microwaves are often refracted by the atmospheric layers. The refracted rays take longer time to reach the destination than the direct rays. This causes out of phase transmission, called multipath fading.
- Microwaves need unidirectional antennas to send out signals. Two types of antennas are needed –
  - **Parabolic Dish Antenna** – It is used by the receiving station. It is parabolic in shape, which concentrates all energy to a small beam thus achieving a strong signal with high SNR.
  - **Horn Antenna** – It has a stem with a curved head. In sending stations, outgoing waves from the stem are broadcast by the curved head as a series of parallel beams. In the receiving station, the rays are collected by the curved head and deflected in the stem.

## Applications

- Long distance telephone communication
- Cellular phones

- Television networks
- Satellites
- Wireless LANs

The basic function of a microwave link is same as that of copper or fiber optic link. Both provide the means of communication system. Co-axial cables and fiber optical cables carry voltage and light signals through them whereas a microwave radio communication system uses electromagnetic waves in microwave range to establish the communication.

Microwave communication system deals with a study of the signal path between the transmitter and receiver.

The signal path depends on the atmosphere medium under microwave communication and signal strength depends upon atmosphere condition, frequency of operation and type of propagation.

**Basic Microwave Communication Link:**

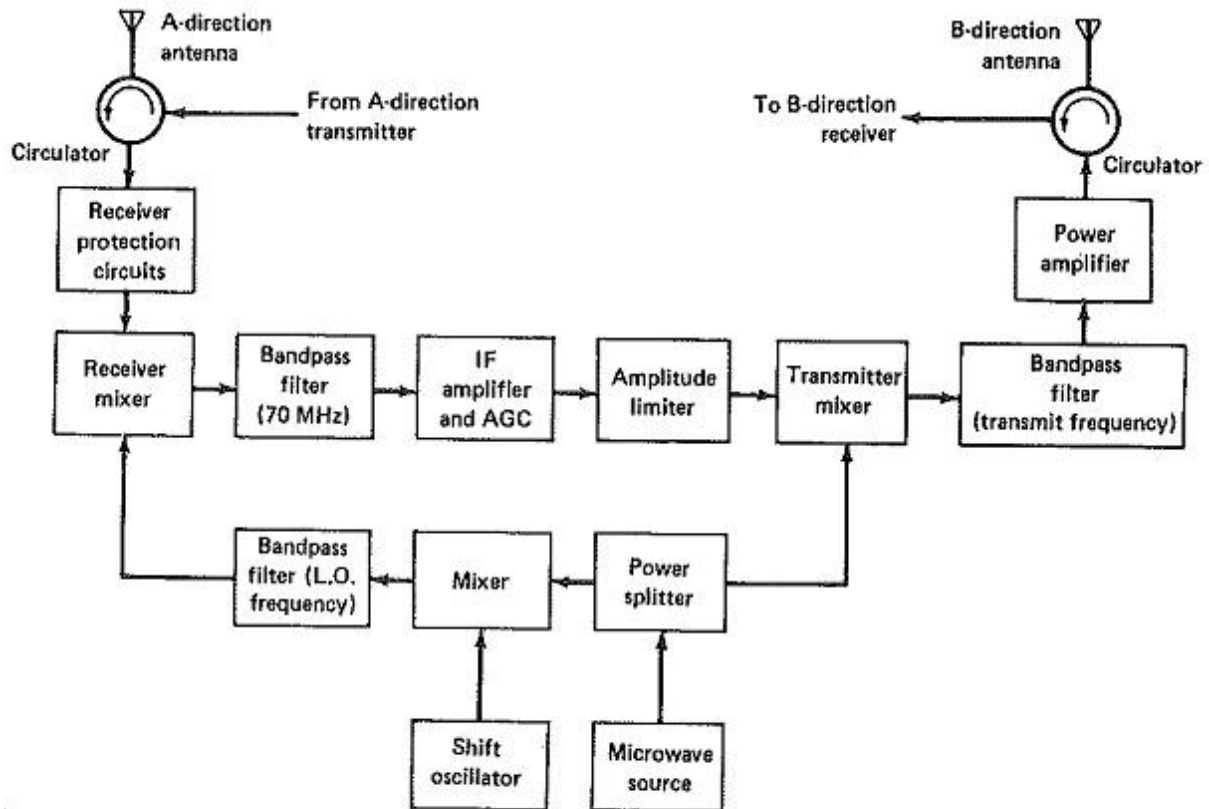

**FIGURE 15-5** Simplified block diagram of microwave link carrier chain, shown receiving from A direction and transmitting in B direction.

Microwave communication link provide the means for the communication system. It uses microwave range to establish the communication range.

The basic blocks are explained below:

**Antenna:** mostly parabolic reflector types of antennas are used. Hog horn type of antennas are used in high density links.

**Circulator:** A circulator is used to isolate transmitter with the receiver input and to couple transmitter to antenna and antenna to receiver input.

**Protection circuitry:** it provides safety to the mixer from overloads

**Mixer (Receiver):** it has two out puts. One is the incoming signal and the other is signal from lower band pass filter. This signal has a frequency which is 70 MHz higher than that of incoming signal. So, mixer gives an IF signal of 70MHz. a Schottky barrier diode is used in the receiver mixer.

**Band Pass Filter:** it provides the necessary selectivity to the receiver.

**IF Amplifier and AGC:** it is responsible for the amplification of the signal. It has many stages and its gain through AGC. It has to be linear broad band and low noise amplifier.

**Amplitude limiter:** As the signal is frequency modulated one so an amplitude limiter is used to avoid unwanted amplitude variations.

**Mixer (Transmitter):** It is used to convert IF frequency to transmitting microwave frequency. Generally, varactor diode are employed in this mixer.

**Power Amplifier:** Transmitted power from a repeater station can be in the the range of .25 W to 10 W. When the required transmitted power (depending on the distance repeater) is in the range of 1 to 5 W and frequency below 6 GHz, FET power amplifiers are generally used. When the power is above 5 W and frequencies above 6 GHz, TWT are used for amplification.

**Microwave source:** Earlier klystron and gunn oscillators were used as source of microwave frequencies. Now, VHF transistor crystal oscillators has taken their place which is used with a varactor multiplier.

**Power Splitter:** It divides the output power from a microwave source and feeds a large portion to the transmitter mixer which converts it to transmitting microwave frequency. The second portion is fed to the balanced mixer.

**Shift Oscillator:** It provides one of the input to the balanced in such a way that output frequency from the balanced mixer is such that it produces 70 MHz IF at the output of receiver mixer.

A microwave link generally incorporates 600-2700 channels per carrier. And number of carriers in each direction can be 4 to 12.

The most common example of microwave repeater station is tower erected by mobile companies which have approximate height of 25 meters. These are located in remote areas so as to have their own uninterruptible power supplies backed by batteries.

No full time attendant is there with any repeater.

## **TROPOSPHERE:**

The **troposphere** is the lowest layer of Earth's atmosphere, and is also where nearly all weather conditions take place. The lowest region of the atmosphere, extending from the earth's surface to a height of about 6–10 km.

### **Properties of Troposphere:**

- Most of the mass (about 75-80%) of the atmosphere is in the troposphere. Most types of clouds are found in the troposphere.
- Almost all weather occurs within this layer.
- The troposphere is by far the wettest layer of the atmosphere; all of the layers above contain very little moisture.

The bottom of the troposphere is at Earth's surface. The troposphere extends upward to about 10 km (6.2 miles or about 33,000 feet) above sea level. The height of the top of the troposphere varies with latitude (it is lowest over the poles and highest at the equator) and by season (it is lower in winter and higher in summer).

- It can be as high as 20 km (12 miles or 65,000 feet) near the equator, and as low as 7 km (4 miles or 23,000 feet) over the poles in winter.
- Air is warmest at the bottom of the troposphere near ground level. Air gets colder as one rises through the troposphere. That's why the peaks of tall mountains can be snow-covered even in the summertime.
- Air pressure and the density of the air also decrease with altitude. That's why the cabins of high-flying jet aircraft are pressurized.
- The layer immediately above the troposphere is called the stratosphere. The boundary between the troposphere and the stratosphere is called the "tropopause".

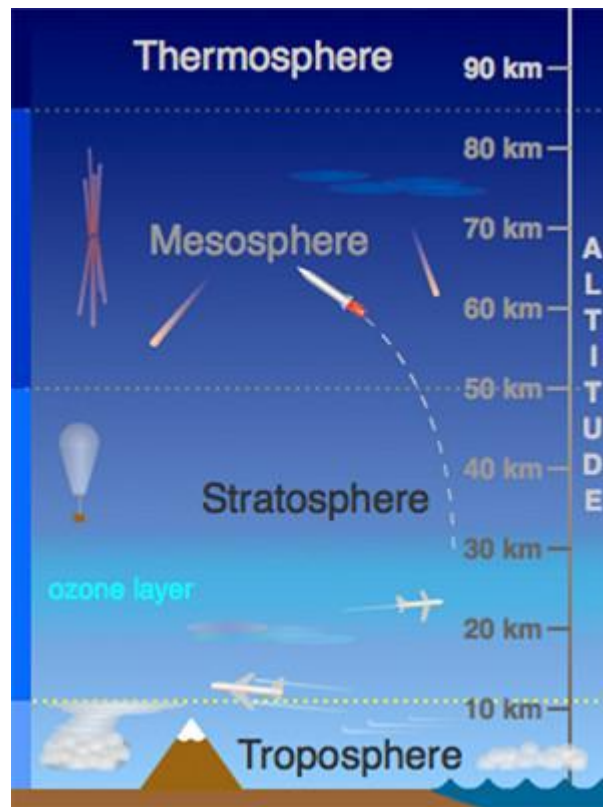

•

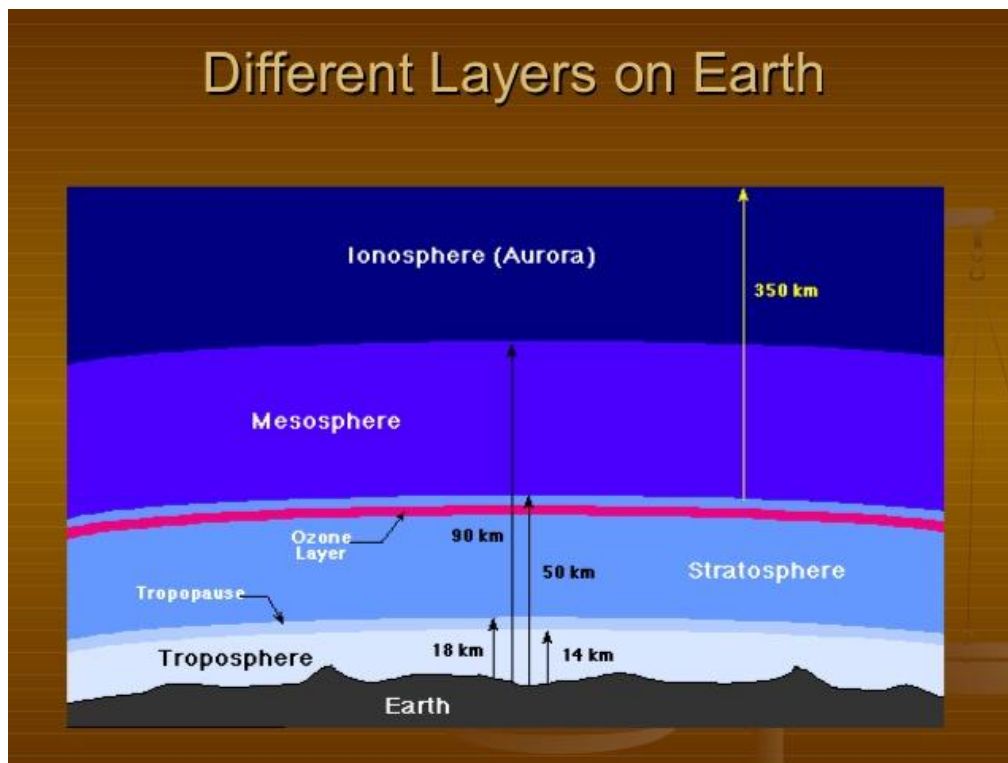

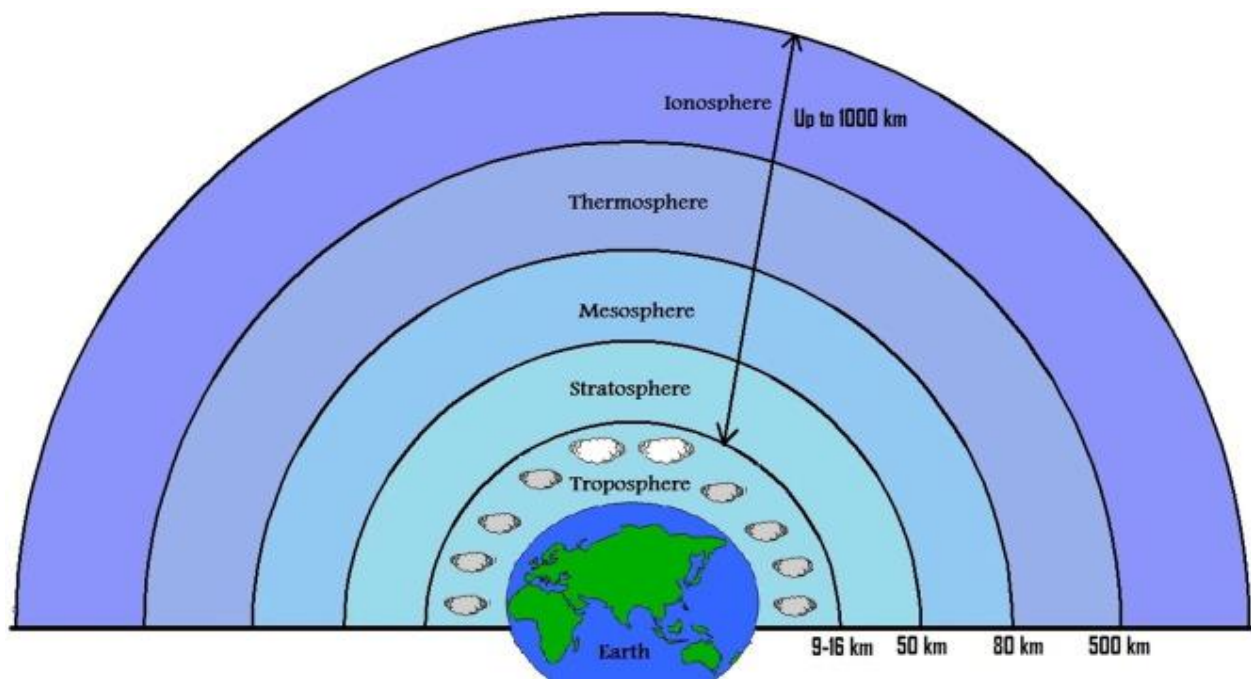

## **Troposcatter Communications :**

As the name implies, troposcatter uses the troposphere as the region that affects the radio signals being transmitted, returning them to Earth so that they can be received by the distant receiver. Troposcatter relies on the fact that there are areas of slightly different dielectric constant in the atmosphere at an altitude of between 2 and 5 kilometres.

Troposcatter is most pronounced at UHF and microwave radio frequencies (300 MHz and above). Mostly Troposcatter Communication occurs at frequencies of .3-10 GHz. A transmitter launches a high power signal, most of which passes through the atmosphere into outer space. The area within which the scattering takes place is called the scatter volume, and its size is dependent upon the gain of the antennas

Troposcatter Communications are used for beyond line of sight (over the horizon) point to point communications between remote geographic areas where cable links are not feasible.

A troposcatter system has an antenna at both ends, capable of both transmitting and receiving signals, aimed at a fixed point in the troposphere slightly above

the horizon. The common region where the antenna beams intersect is the area where the forward scattering phenomenon takes place.

In troposcatter propagation, when a signal is aimed towards the troposphere, some part of the radio signal is scattered back to the Earth due to forward scattering in the troposphere. This returning signal is received by a receiver at the other end. But in troposcatter propagation, only a small portion of the signal is scattered forward and reaches the receiver, a major part of the signal is either lost in space or reflects in other directions.

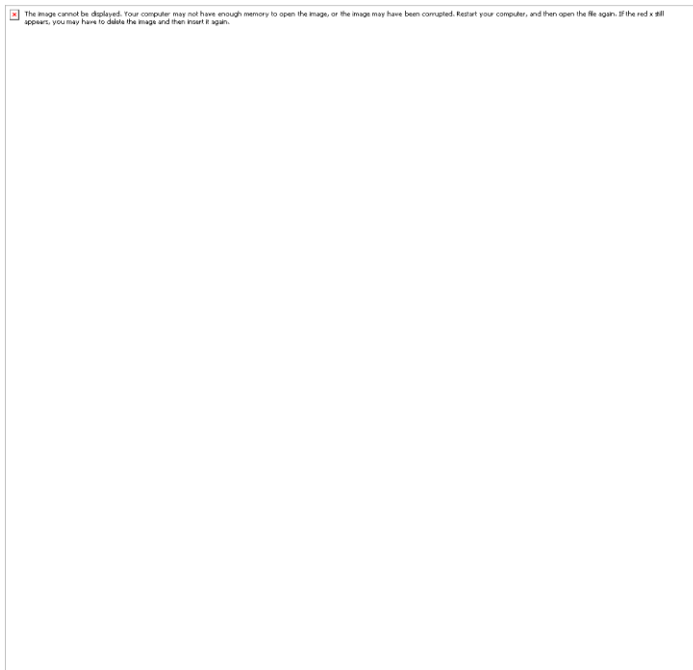
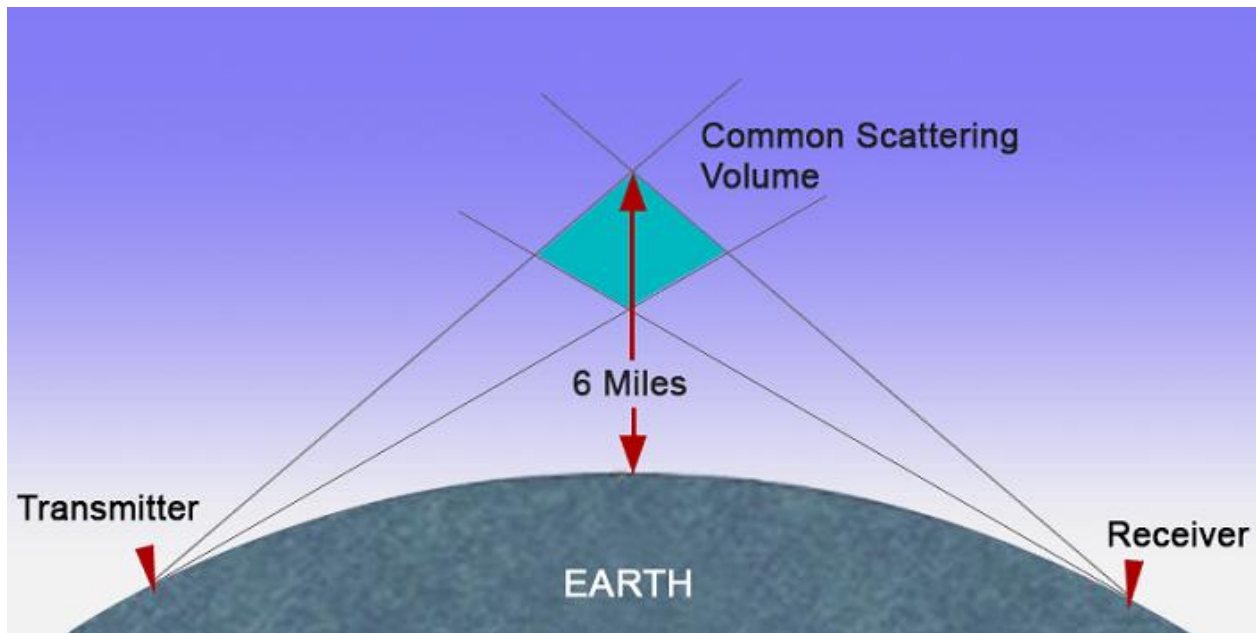

---

### The first two layers of the atmosphere

- **Troposphere** = bottommost layer
  - Air for breathing, weather
  - Temperature declines with altitude
  - **Tropopause** = limits mixing between troposphere and the layer above it
- **Stratosphere** = 11-50 km (7-31 mi) above sea level
  - Drier and less dense, with little vertical mixing
  - Colder in its lower regions
  - Contains UV radiation-blocking ozone, 17-30 km (10-19 mi) above sea level

Copyright © 2008 Pearson Education, Inc., publishing as Pearson Benjamin Cummings

#### **APPLICATIONS:**

- Troposcatter is often used for commercial radio communications applications, normally on frequencies above 500 MHz for over the horizon links.
- It is ideal for remote telemetry, or other links where low to medium rate data needs to be carried.
- Troposcatter provides a means of communication that is much cheaper than using satellites.

- Troposcatter requires high power transmitters, sensitive receivers and high gain antennas, it provides a very convenient data transmission system for many radio communications applications
- It is used in various communication systems like
  - ❖ A line of sight communication and satellite communication
  - ❖ Radar communication
  - ❖ Microwave linking

### Space wave propagation limitations

- These waves are affected by the curvature of the earth.
- The propagation of these waves happens along the line of sight distance which is defined as the distance between the transmitting antenna and the receiving antenna which is also known as the range of communication.

### Tropospheric Scatter Propagation

The technique is of practical importance at VHF, UHF and Microwaves.

The UHF and Microwave Signals are found to be propagated much beyond to the Line of Sight Propagation through the forward scattering in the tropospheric irregularities.

The Mode of Propagation which uses properties of scattering in Troposphere is known as Tropospheric Scatter Propagation.

Here comes a term, the method for improving the reliability of troposcatter links is known as Diversity Operations.

## DUCT PROPAGATION:

A layer of troposphere bounded above and below by layers that have different refractive index, which confines and propagates an abnormally high proportion of VHF (very high frequency) and UHF (ultrahigh frequency) radiation. This results in freak long-distance communications and radar pickup ranges.

This is normally caused by an inversion layer. The thickness of such a layer is seldom more than 100 m (300 ft). Layers caused by temperature inversions form ducts that can carry signals much farther than typical line of sight communications

## Duct Propagation

### Temperature Inversion / Troposphere Ducting:

Certain weather conditions produce a layer of air in the Troposphere that will be at a higher temperature than the layers of air above and below it. Such a layer will provide a "**duct**" creating a path through the warmer layer of air which has less signal loss than cooler layers above and below.

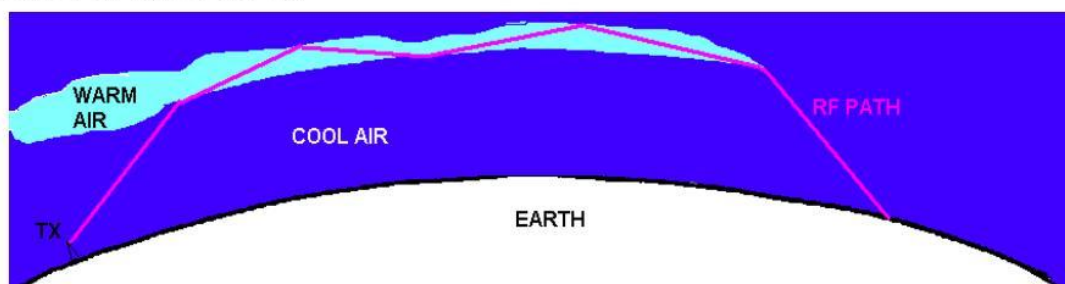

The increase of temperature with height, rather than the decrease in the temperature is known as the phenomenon of **temperature inversion**.

**TYPES OF PROPAGATION:**

## TYPES OF PROPAGATION

<GROUND WAVE PROPAGATION  
 <SKY WAVE PROPAGATION  
 <SPACE WAVE PROPAGATION

## Three types of wave propagation

Classification Band	Initials	Frequency Range	Characteristics
Extremely low	ELF	< 300 Hz	Ground wave
Infra low	ILF	300 Hz - 3 kHz	
Very low	VLF	3 kHz - 30 kHz	
Low	LF	30 kHz - 300 kHz	
Medium	MF	300 kHz - 3 MHz	Ground/Sky wave
High	HF	3 MHz - 30 MHz	Sky wave
Very high	VHF	30 MHz - 300 MHz	Space wave
Ultra high	UHF	300 MHz - 3 GHz	
Super high	SHF	3 GHz - 30 GHz	
Extremely high	EHF	30 GHz - 300 GHz	
Tremendously high	THF	300 GHz - 3000 GHz	

## Ground Propagation:

It is a method of propagation, in which radio waves travel through the lowest layers of the atmosphere along the earth's surface, following the earth's curvature. The frequency of these signals is low ( $\leq 2\text{MHz}$ ), and the distance they travel is directly proportional to the power in signal.

- **A ground wave is an electromagnetic wave that travels along the surface of earth. Therefore, ground wave is sometimes called surface waves. Ground waves must be vertically polarized.**

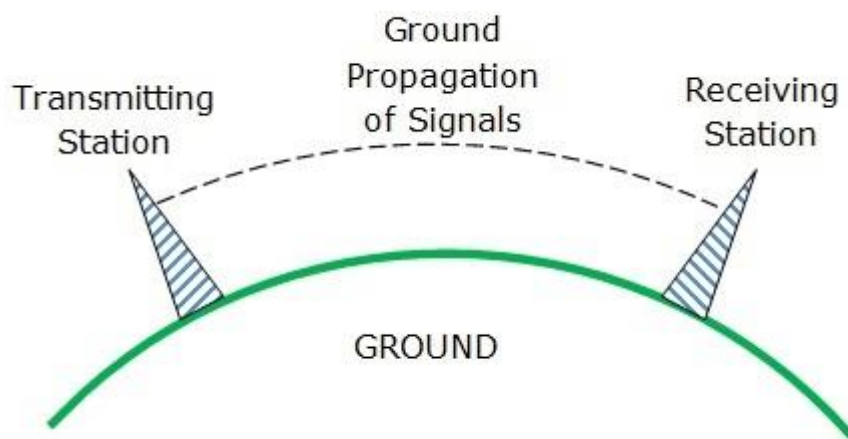

## Ground-Wave Propagation

- At frequencies up to about 2 MHz, the most important method of propagation is by *ground waves* which are vertically polarized. They follow the curvature of the earth to propagate far beyond the horizon. Relatively high power is required.

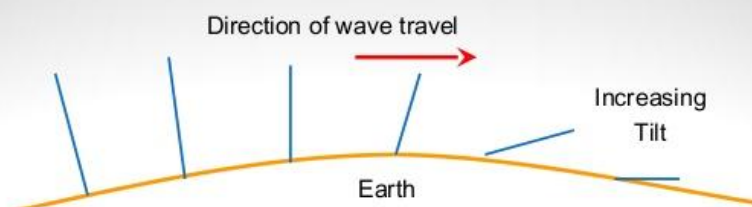

# GROUND-WAVE PROPAGATION

- Dominant mode of propagation for frequencies **below 2 MHz**.
- Diffraction of the wave causes the wave to propagate **along the surface of the earth**.
- This propagation mode is used in **AM Radio Broadcasting**.
- Diffraction of waves in "D" layer helps propagation along the surface of earth.

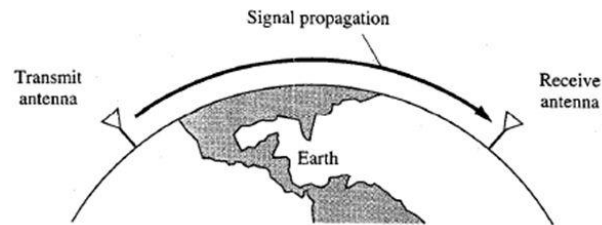

(a) Ground-Wave Propagation (Below 2 MHz)



**Sky Wave Propagation**: In sky propagation, high frequency radio waves (2–30 MHz) are reflected back from the ionosphere towards the earth's surface. They can be used to transmit signals over a large geographical area since their distance is not bounded by the earth's curvature

**Sky wave are Electromagnetic waves that propagate above the horizon level**

# SKY-WAVE PROPAGATION

- Dominant mode of propagation for EM waves in the frequency range of **2 MHz to 30 MHz**.
- **Long coverage** is obtained by reflection of wave at the ionosphere and at the Earth's boundary.
- This mode is used in HF band **International Broadcasting (Shortwave Radio)**.
- Sky-wave propagation is caused primarily by reflection from the F layer (90 to 250 miles in altitude).

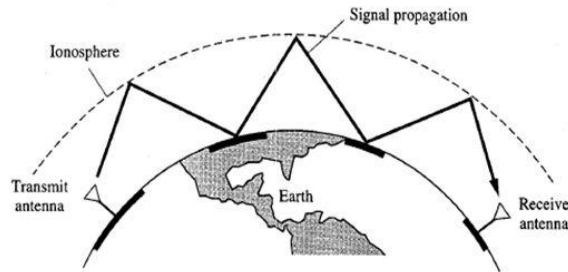

(b) Sky-Wave Propagation (2 to 30 MHz)

Eeng360 9

## Line – of – Sight Propagation( Space Wave Propagation)

In line – of – sight propagation, very high frequency waves (  $> 30$  MHz ) travel at straight lines from the source antenna (transmitter) to the destination antenna (receiver). These waves are easily disrupted by present of objects in their path. So the antennas are placed tall enough above obstructions. They are unidirectional facing each other.

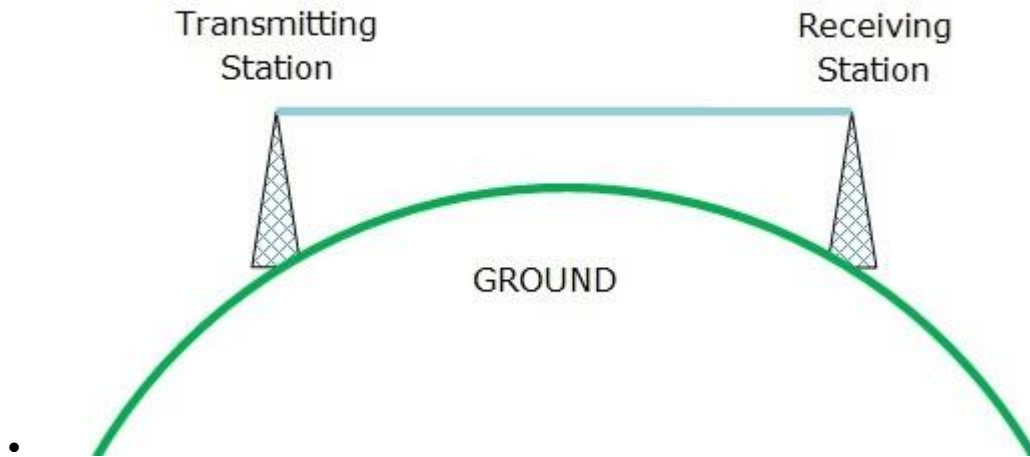

Space wave propagation of electromagnetic energy includes radiated energy that travels in the lower few miles of earth 'atmosphere. Space wave includes both direct and grounded reflected waves. Space wave propagation with direct waves is commonly called Line of Sight Transmission.

## SPACE WAVE PROPAGATION

- The radio waves having **high frequencies** are basically called as **space waves**.
- The other name of space wave propagation is **line of sight propagation (LOS)**
- These waves have the ability to propagate through atmosphere, from transmitter antenna to receiver antenna.
- These waves can travel directly or can travel after reflecting from earth's surface to the troposphere surface of earth.
- So, it is also called as Tropospheric Propagation. In the diagram of medium wave propagation, c shows the space wave propagation.

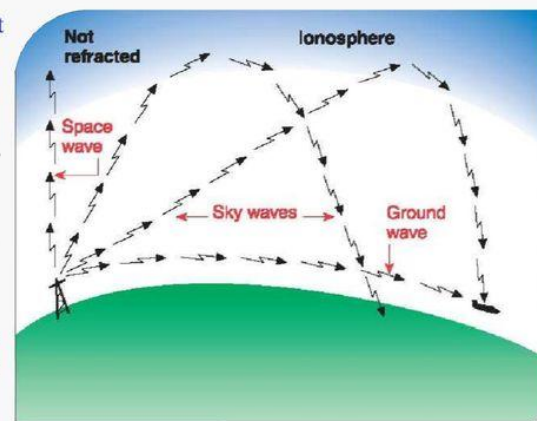

Figure 7-1. Ground, space, and sky wave propagation.

Frequency Range of Troposphere Scatter Propagation (30 MHz to 300 MHz)

The **space waves** can travel through atmosphere from transmitter antenna to receiver antenna either directly or after reflection from ground in the earth's troposphere region.

## Radar System

RADAR stands for Radio Detection and Ranging System.

- **Radar** is a detection system that uses radio waves to determine the range, angle, or velocity of objects.
- It can be used to detect aircraft, ships, spacecraft, guided missiles, motor vehicles, weather formations, and terrain.
- A radar system consists of a
  - ❖ transmitter producing electromagnetic waves in the radio or microwaves domain,
  - ❖ a transmitting antenna,
  - ❖ a receiving antenna (often the same antenna is used for transmitting and receiving)
  - ❖ a receiver
  - ❖ processor to determine properties of the object(s).

It works by radiating energy into space and monitoring the echo or reflected signal from the objects. It operates in the UHF and microwave range. Radio waves (pulsed or continuous) from the transmitter reflect off the object and return to the receiver, giving information about the object's location and speed.

## Radar Principle

The electromagnetic pulses strike an object and are reflected back to the antenna.

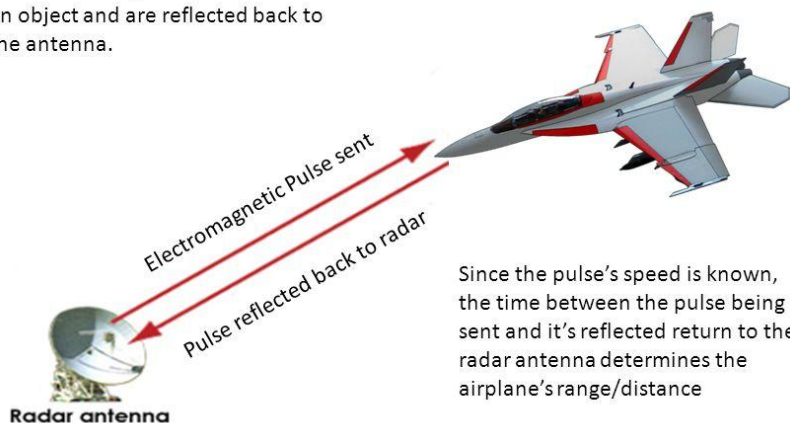

Since the pulse's speed is known, the time between the pulse being sent and it's reflected return to the radar antenna determines the airplane's range/distance

$$\text{Distance} = \text{Speed} \times \text{Time}$$



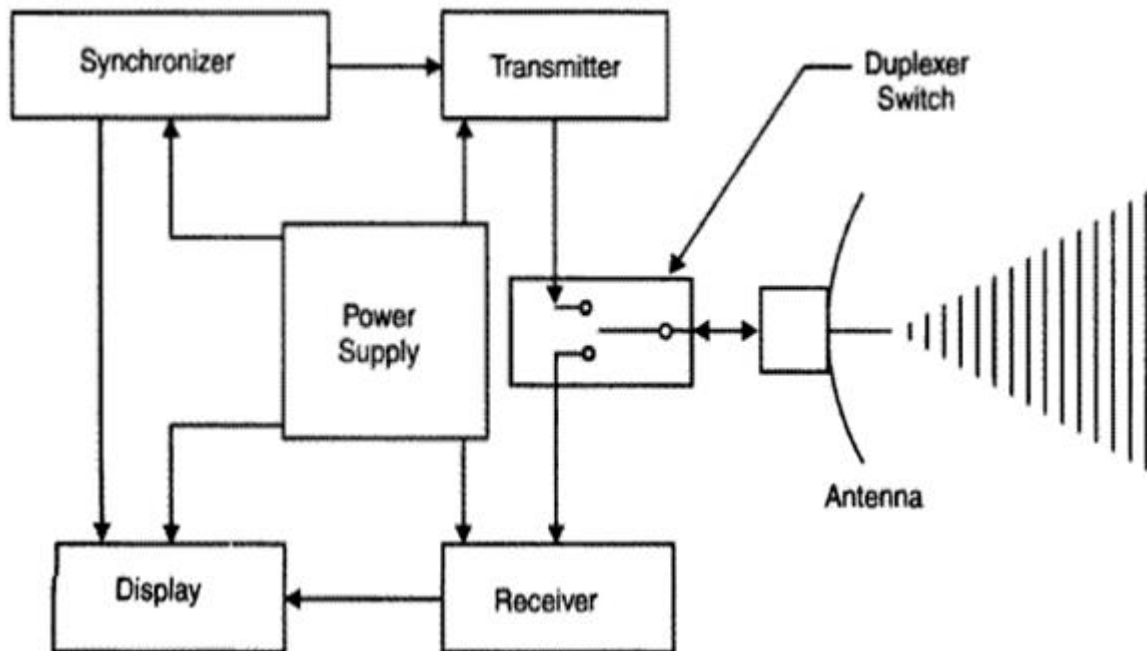

- **Transmitter:** It can be a power amplifier like a Klystron, Travelling Wave Tube or a power Oscillator like a Magnetron. The signal is first generated using a waveform generator and then amplified in the power amplifier.
- **Waveguides:** The waveguides are transmission lines for transmission of the RADAR signals.
- **Antenna:** The antenna used can be a parabolic reflector, planar arrays or electronically steered phased arrays.
- **Duplexer:** A duplexer allows the antenna to be used as a transmitter or a receiver. It can be a gaseous device that would produce a short circuit at the input to the receiver when transmitter is working.
- **Receiver:** It can be super heterodyne receiver or any other receiver which consists of a processor to process the signal and detect it.
- **Threshold Decision:** The output of the receiver is compared with a threshold to detect the presence of any object. If the output is below any threshold, the presence of noise is assumed.

## **RADAR Applications :**

### ❖ **Military Applications:**

- In air defense it is used for target detection, target recognition and weapon control (directing the weapon to the tracked targets).
- In missile system to guide the weapon.
- Identifying enemy locations in map.

### ❖ **Air Traffic Control:**

- To control air traffic near airports. The Air Surveillance RADAR is used to detect and display the aircraft's position in the airport terminals.
- To guide the aircraft to land in bad weather using Precision Approach RADAR.
- To scan the airport surface for aircraft and ground vehicle positions

### ❖ **Remote Sensing:**

- RADAR can be used for observing weather or observing planetary positions and monitoring sea ice to ensure smooth route for ships.

### ❖ **Ground Traffic Control:**

- RADAR can also be used by traffic police to determine speed of the vehicle, controlling the movement of vehicles by giving warnings about presence of other vehicles or any other obstacles behind them.

### • **Space**

- To guide the space vehicle for safe landing on moon
- To observe the planetary systems
- To detect and track satellites
- To monitor the meteors

# FIELDS OF APPLICATION

- ✦ MILITARY
- ✦ REMOTE SENSING
- ✦ AIR TRAFFIC CONTROL
- ✦ LAW ENFORCEMENT AND HIGHWAY SECURITY
- ✦ AIRCRAFT SAFETY AND NAVIGATION
- ✦ SHIP SAFETY
- ✦ SPACE
- ✦ MISCELLANEOUS APPLICATIONS

Radars can be classified into the following two types based on the type of signal with which Radar can be operated.

- **Pulse Radar**
- **Continuous Wave Radar**

## **Pulse Radar**

The Radar, which operates with pulse signal is called the **Pulse Radar**. Pulse Radars can be classified into the following two types based on the type of the target it detects.

- Basic Pulse Radar
- Moving Target Indication Radar

### ❖ **Basic Pulse Radar**

The Radar, which operates with pulse signal for detecting stationary targets, is called the **Basic Pulse Radar** or simply, Pulse Radar. It uses single Antenna for both transmitting and receiving signals with the help of Duplexer.

Antenna will transmit a pulse signal at every clock pulse. The duration between the two clock pulses should be chosen in such a way that the echo signal corresponding to the present clock pulse should be received before the next clock pulse.

#### ❖ Moving Target Indication Radar

The Radar, which operates with pulse signal for detecting non-stationary targets, is called Moving Target Indication Radar or simply, **MTI Radar**. It uses single Antenna for both transmission and reception of signals with the help of Duplexer.

MTI Radar uses the principle of **Doppler effect** for distinguishing the non-stationary targets from stationary objects.

### Continuous Wave Radar

The Radar, which operates with continuous signal or wave is called **Continuous Wave Radar**. They use Doppler Effect for detecting non-stationary targets. Continuous Wave Radars can be classified into the following two types.

- Unmodulated Continuous Wave Radar
- Frequency Modulated Continuous Wave Radar

#### ❖ Unmodulated Continuous Wave Radar

The Radar, which operates with continuous signal (wave) for detecting non-stationary targets is called Unmodulated Continuous Wave Radar or simply, **CW Radar**. It is also called CW Doppler Radar.

This Radar requires two Antennas. Of these two antennas, one Antenna is used for transmitting the signal and the other Antenna is used for receiving the signal. It measures only the speed of the target but not the distance of the target from the Radar.

### ❖ Frequency Modulated Continuous Wave Radar

If CW Doppler Radar uses the Frequency Modulation, then that Radar is called the Frequency Modulated Continuous Wave (**FMCW**) Radar or FMCW Doppler Radar. It is also called Continuous Wave Frequency Modulated Radar or CWFm Radar.

This Radar requires two Antennas. Among which, one Antenna is used for transmitting the signal and the other Antenna is used for receiving the signal. It measures not only the speed of the target but also the distance of the target from the Radar

### Radar Range Equation:

We know that **Power density** is nothing but the ratio of Power and Area. So, the power density,  $P_d$  at a distance,  $R$  from the Radar (Assuming that the Power is radiating in all directions) can be mathematically represented as –

$$\text{Power Density } (P_d) = P_t / 4\pi R^2 \quad (1)$$

Where,

$P_t$  is the amount of power transmitted by the Radar transmitter

$4\pi R^2$  represents the area of a sphere with radius  $R$

The above power density is valid for an isotropic Antenna. In general, Radars use directional Antennas. Therefore, the power density, due to directional Antenna will be –

$$P_d = P_t * G_t / 4\pi R^2 \quad (2)$$

Where  $G_t$  = Gain of Antenna

This is the radiated power density of the directive antenna. The target intercepts and reflects part of this energy. The Portion of the power reflected by the target in the direction of the receiving antenna will depend on the target scattering characteristics.

The amount of power, which is reflected back towards the Radar depends on its cross section.

$$\begin{aligned} \text{Reflected Power from the target} &= P_t * G * \sigma / 4\pi R^2 \\ \text{target cross section} &= \sigma \end{aligned}$$

So, the power density of reflected target power ( $P_{dr}$ ) of echo signal at Radar can be mathematically represented as –

$$P_{dr} = P_t * G * \sigma / (4\pi R^2)^2 \quad (3)$$

The amount of **power**,  $P_r$  **received** by the Radar depends on the effective aperture,  $A_e$  of the receiving Antenna.

$$P_r = P_t * G * \sigma * A_e / (4\pi R^2)^2 \quad (4)$$

From here we calculate R( Range)

$$R = [P_t * G * \sigma * A_e / (4\pi)^2 P_r]^{1/4} \quad (5)$$

When  $P_r = S_{min}$ ,  $R = R_{max}$

$$R_{max} = [P_t * G * \sigma * A_e / (4\pi)^2 S_{min}]^{1/4} \quad (6)$$

Gain of directional Antenna,  $G$  and effective aperture,  $A_e$ .

$$G = 4\pi A_e / \lambda^2 \quad (7)$$

Putting value of (7) in Equation (6)

$$\Rightarrow R_{Max} = [P_t G \sigma A_e^2 / 4 \pi \lambda^2 S_{min}]^{1/4}$$

$$A_e = G \lambda^2 / 4\pi$$

$$R_{max} = \sqrt[4]{\frac{P_t G^2 \lambda^2 \sigma}{(4\pi)^3 P_{min}}}$$

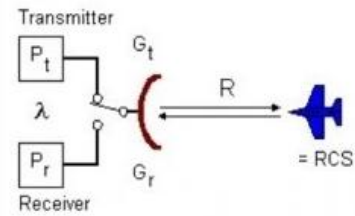

Where,

$R_{max}$  = Radar Range

$P_t$  = Transmitted Pulse Peak Power

$G$  = Maximum Power Gain of Antenna

$A_e$  = Antenna Aperture

$\sigma$  = Radar Cross Section Area (RCS)

$P_{min}$  = Minimum Detectable Signal of Receiver

### Block Diagram of Pulse Radar

Pulse Radar uses single Antenna for both transmitting and receiving of signals with the help of Duplexer. It is widely used for detecting range of objects. Following is the **block diagram** of Pulse Radar –

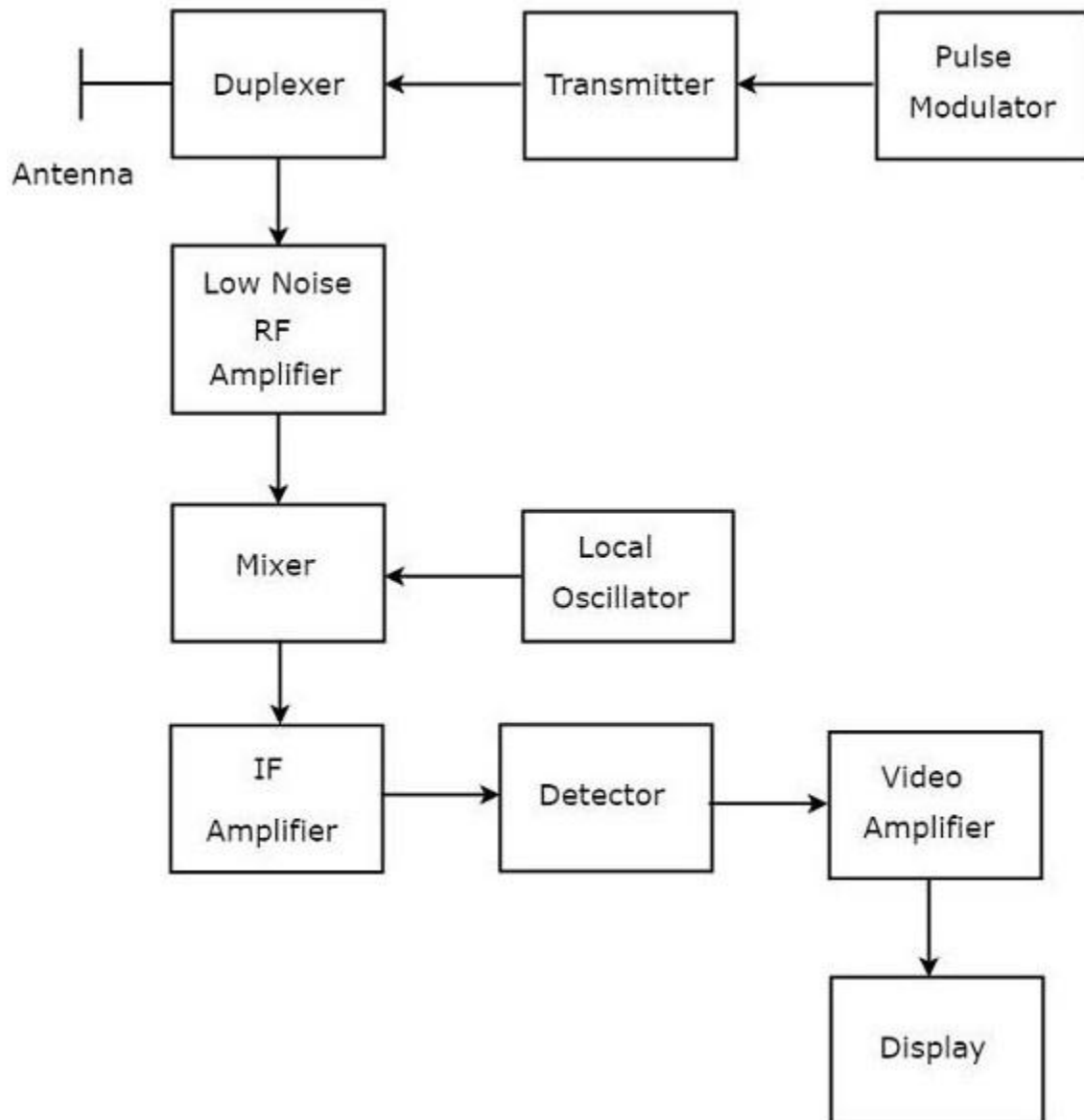

Let us now see the **function** of each block of Pulse Radar –

- **Pulse Modulator** – It produces a pulse-modulated signal and it is applied to the Transmitter.
- **Transmitter** – It transmits the pulse-modulated signal, which is a train of repetitive pulses.
- **Duplexer** – It is a microwave switch, which connects the Antenna to both transmitter section and receiver section alternately. Antenna transmits the pulse-modulated signal, when the duplexer connects the Antenna to the transmitter. Similarly, the signal, which is received by Antenna will be given to Low Noise RF Amplifier, when the duplexer connects the Antenna to Low Noise RF Amplifier.

- **Low Noise RF Amplifier** – It amplifies the weak RF signal, which is received by Antenna. The output of this amplifier is connected to Mixer.
- **Local Oscillator** – It produces a signal having stable frequency. The output of Local Oscillator is connected to Mixer.
- **Mixer** – We know that Mixer can produce both sum and difference of the frequencies that are applied to it. Among which, the difference of the frequencies will be of Intermediate Frequency (IF) type.
- **IF Amplifier** – IF amplifier amplifies the Intermediate Frequency (IF) signal. The IF amplifier shown in the figure allows only the Intermediate Frequency, which is obtained from Mixer and amplifies it. It improves the Signal to Noise Ratio at output.
- **Detector** – It demodulates the signal, which is obtained at the output of the IF Amplifier.
- **Video Amplifier** – As the name suggests, it amplifies the video signal, which is obtained at the output of detector.
- **Display** – In general, it displays the amplified video signal on CRT screen.

### **Benefits or advantages of Pulsed Radar**

Following are the benefits or **advantages of Pulsed Radar**:

- ➔ Pulse doppler radar is used to reject unwanted echoes using doppler filters.
- ➔ It can measure range and velocity in the presence of multiple targets.
- ➔ It offers higher S/N ratio.
- ➔ Medium PRF pulsed radar offers better range accuracy and range resolution.
- ➔ It offers better performance for airborne low speed targets.

### **Drawbacks or disadvantages of Pulsed Radar**

Following are the **disadvantages of Pulsed Radar**:

- ➔ High PRF pulsed radar has poor range accuracy and target resolution is also

poor. Moreover it has range ambiguities.

➔Medium PRF pulsed radar does not have any clutter free region.

### **UNAMBIGUOUS RANGE:**

The Range beyond which target appears as second time around echos is known as maximum ambiguous range.

The maximum unambiguous range ( $R_{max}$ ) is the longest range that can be detected by transmitting a pulse which travel round trip and still produce reliable information.

$$R_{unamb} = C * PRT/2$$

Where C= Velocity of Light

PRT= Pulse Repetition Frequency

## Maximum Unambiguous Range

- Once the radar Tx transmits a pulse, sufficient time should be allotted so that the echo signal due to this pulse may be received and detected before the next pulse is transmitted.
- If the prf is too high echoes may arrive after the transmission of the next pulse. Such echoes are called “Second time around echoes”

$$R_{unamb} = \frac{c}{2f_p}$$

# Maximum unambiguous range

- We send a train of pulses. **Not a single pulse**. A pulse is sent and reflected back as echo
- We have **to wait to get for the echo** before we send the next one
- If not the **echo for the first pulse we sent will become echo for the second one**. This is called **second time around pulse**
- **Due to this the target may look near** (as you get the echo immediately for the send pulse: this echo was for the first pulse!!!!)
- So the pulse repetition frequency (PRF) is important and it determines the maximum unambiguous range

$$R_{un} = cT_p/2 = c/2f_p$$

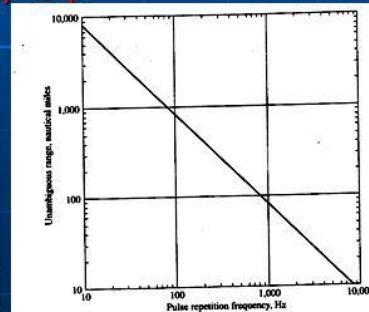
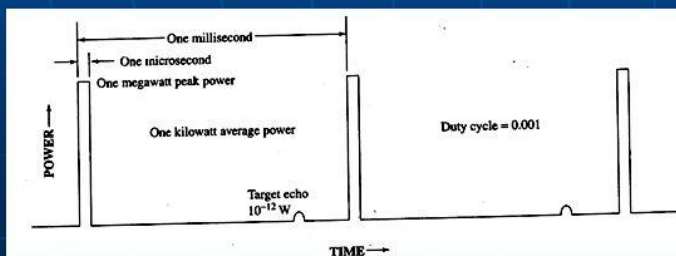

Figure 1.2 Plot of Eq. (1.2), the maximum unambiguous range  $R_{un}$  as a function of the pulse repetition frequency  $f_p$ .

## Doppler Effect:

If the target is not stationary, then there will be a change in the frequency of the signal that is transmitted from the Radar and that is received by the Radar. This effect is known as the Doppler effect.

According to the Doppler effect, we will get the following two possible cases –

- The frequency of the received signal will increase, when the target moves towards the direction of the Radar.
- The frequency of the received signal will decrease, when the target moves away from the Radar.

$$f_d = 2V_r / \lambda$$

Where,

- $f_d$  is the Doppler frequency
- $V_r$  is the relative velocity

OR

$$f_d = 2V_r f / C$$

Where,

- F is the frequency of transmitted signal
  - C is the speed of light and it is equal to  $3 \times 10^8$  m/sec
  - $V_r$  is the relative velocity
- By detecting  $f_d$ , Relative velocity can be found out.

### **MTI RADAR**

MTI stands for Moving Target Indicator. The MTI Radar is used for detecting targets such as aircrafts. It uses Doppler's effect for its working operation. The moving target is detected by cancelling the clutters due to stationary objects like high rise buildings, water tanks etc in the received echo. Clutters are basically the echoes received from the stationary objects. Basically, the moving Target Indicators system compares a set of received echoes with those received during previous sweep. Those echoes whose phase has remained constant are then cancelled out. Phase of stationary objects remain constant but due to moving targets do show a phase change.

## Typical MTI radar (With Power Amplifier)

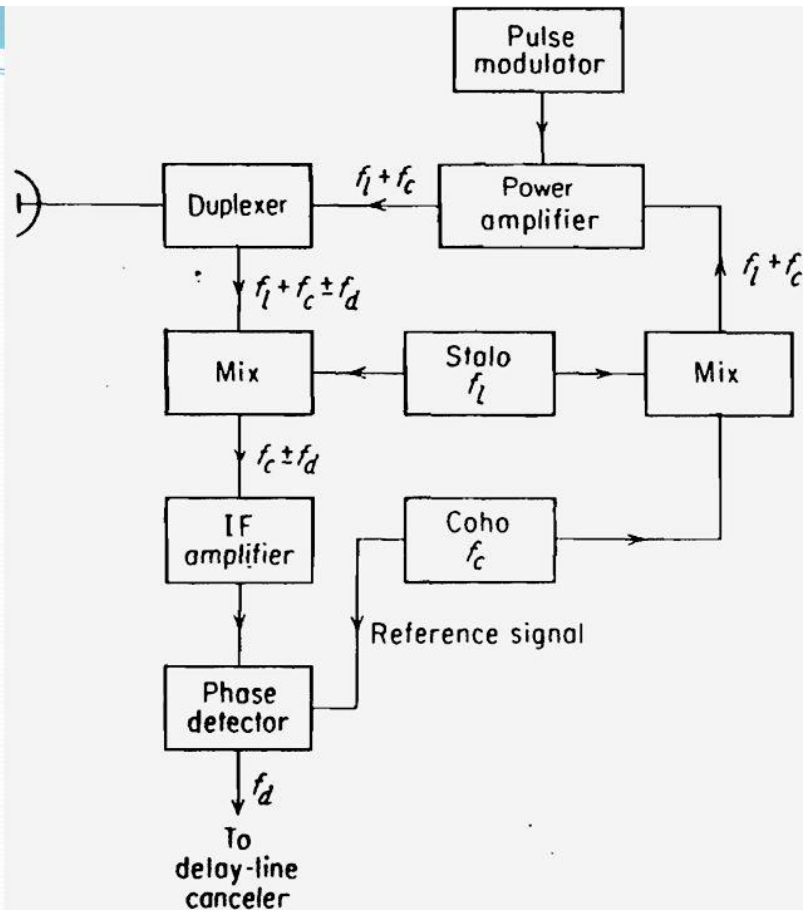

### Delay line canceller

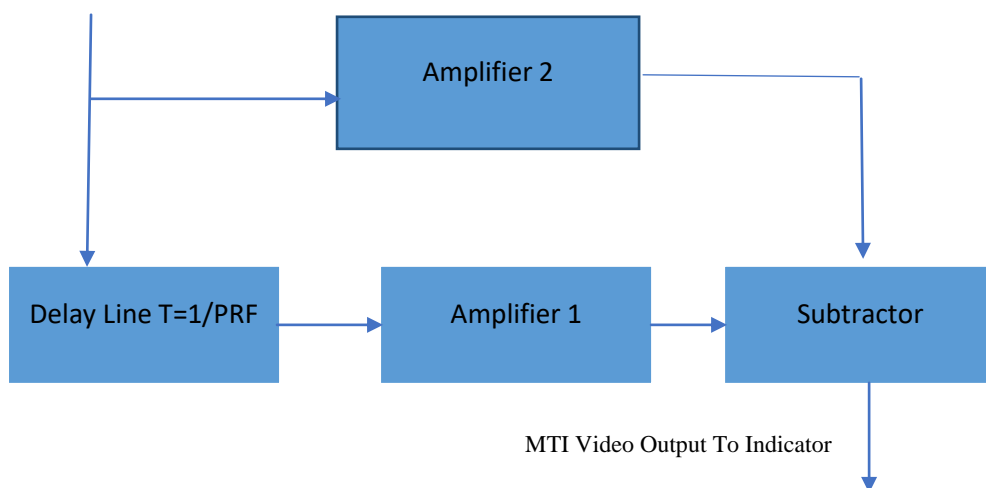

The **function** of each block of MTI Radar with power amplifier transmitter is mentioned below.

- **Pulse Modulator** – It produces a pulse modulated signal and it is applied to Power Amplifier.
- **Power Amplifier** – It amplifies the power levels of the pulse modulated signal.
- **Local Oscillator** – It produces a signal having stable frequency  $f_l$ . Hence, it is also called stable Local Oscillator. The output of Local Oscillator is applied to both Mixer-I and Mixer-II.
- **Coherent Oscillator** – It produces a signal having an Intermediate Frequency,  $f_c$ . This signal is used as the reference signal. The output of Coherent Oscillator is applied to both Mixer-I and Phase Detector.
- **Mixer-I** – Mixer can produce either sum or difference of the frequencies that are applied to it. The signals having frequencies of  $f_l$  and  $f_c$  are applied to Mixer-I. Here, the Mixer-I is used for producing the output, which is having the frequency  $f_l+f_c$ .
- **Duplexer** – It is a microwave switch, which connects the Antenna to either the transmitter section or the receiver section based on the requirement. Antenna transmits the signal having frequency  $f_l+f_c$  when the duplexer connects the Antenna to power amplifier. Similarly, Antenna receives the signal having frequency of  $f_l+f_c\pm f_d$  when the duplexer connects the Antenna to Mixer-II.
- **Mixer-II** – Mixer can produce either sum or difference of the frequencies that are applied to it. The signals having frequencies  $f_l+f_c\pm f_d$  and  $f_l$  are applied to Mixer-II. Here, the Mixer-II is used for producing the output, which is having the frequency  $f_c\pm f_d$ .
- **IF Amplifier** – IF amplifier amplifies the Intermediate Frequency (IF) signal. The IF amplifier shown in the figure amplifies the signal having frequency  $f_c\pm f_d$ . This amplified signal is applied as an input to Phase detector.
- **Phase Detector** – It is used to produce the output signal having frequency  $f_d$  from the applied two input signals, which are having the frequencies of  $f_c+f_d$  and  $f_c$ . The detector compares the IF signal with the

reference signal from COHO oscillator. This phase difference is the Doppler Frequency. Phase detector gives the output both for fix and moving targets. Phase difference is constant for all fixed targets but varies for moving targets. The output of phase detector can be connected to Delay line canceller.

- **Delay Line:** Delay line subtract the output for each pulse from preceding one by delaing earlier ouput by time equal to pulse interval( $1/PRF$ )

**For Fixed Targets, the magnitude and Polarity of the Output will remain the same, However Output'magnitude Will change for Moving targets.**

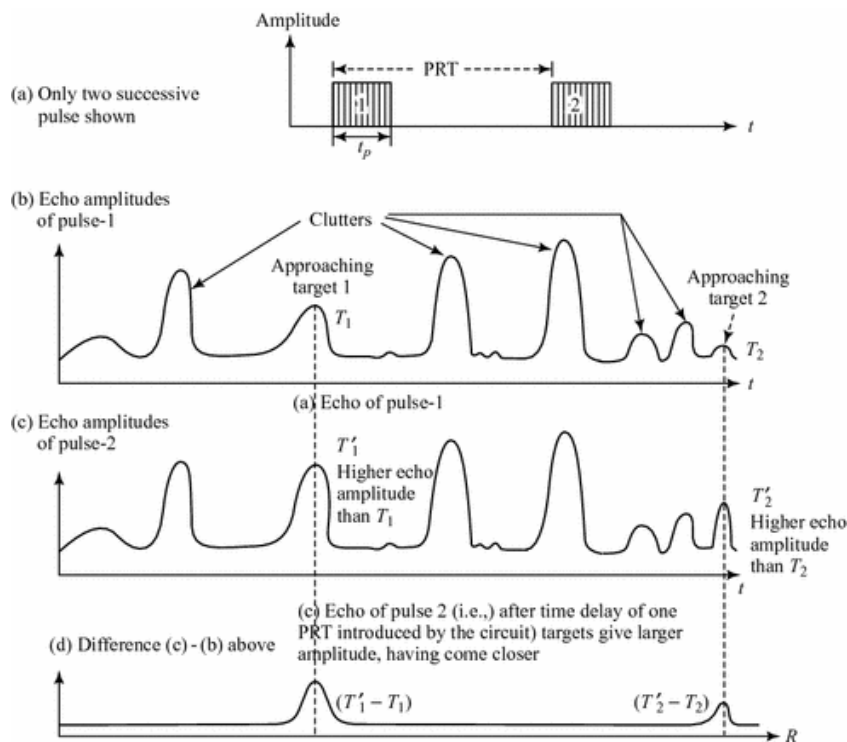

## Benefits or advantages of MTI Radar

Following are the benefits or **advantages of MTI Radar**:

- ➔ MTI radar can distinguish between moving target and stationary target.
- ➔ It uses low PRF (Pulse Repetition Frequency) to avoid range ambiguities.
- ➔ MTI principle is used in air surveillance radar which operates in presence of clutter.
- ➔ It is simpler compare to pulse doppler radar.
- ➔ Antenna bandwidth is high.

- ➔It is economical.
- ➔It does not require waveforms with multiple PRF.
- ➔It is preferred at UHF frequencies.

### **Drawbacks or disadvantages of MTI Radar**

Following are the **disadvantages of MTI Radar**:

- ➔Blind speed does not get detected by pulse MTI radar. Blind speed is defined as magnitude of radial component of velocity of target when moving target appears as stationary target.
- ➔They can have doppler ambiguities.

### **Continuous Wave RADAR**

As opposed to pulsed radar systems, continuous wave (CW) radar systems emit electromagnetic radiation at all times. The Radar, which operates with continuous signal (wave) for detecting non-stationary targets, is called Continuous Wave Radar or simply CW Radar. This Radar requires two Antennas. Among which, one Antenna is used for transmitting the signal and the other Antenna is used for receiving the signal.

CW Doppler Radars give accurate measurement of relative velocities. Hence, these are used mostly, where the information of velocity is more important than the actual range. In a CW RADAR electromagnetic radiation is emitted instead of pulses. It is basically used for speed measurement.

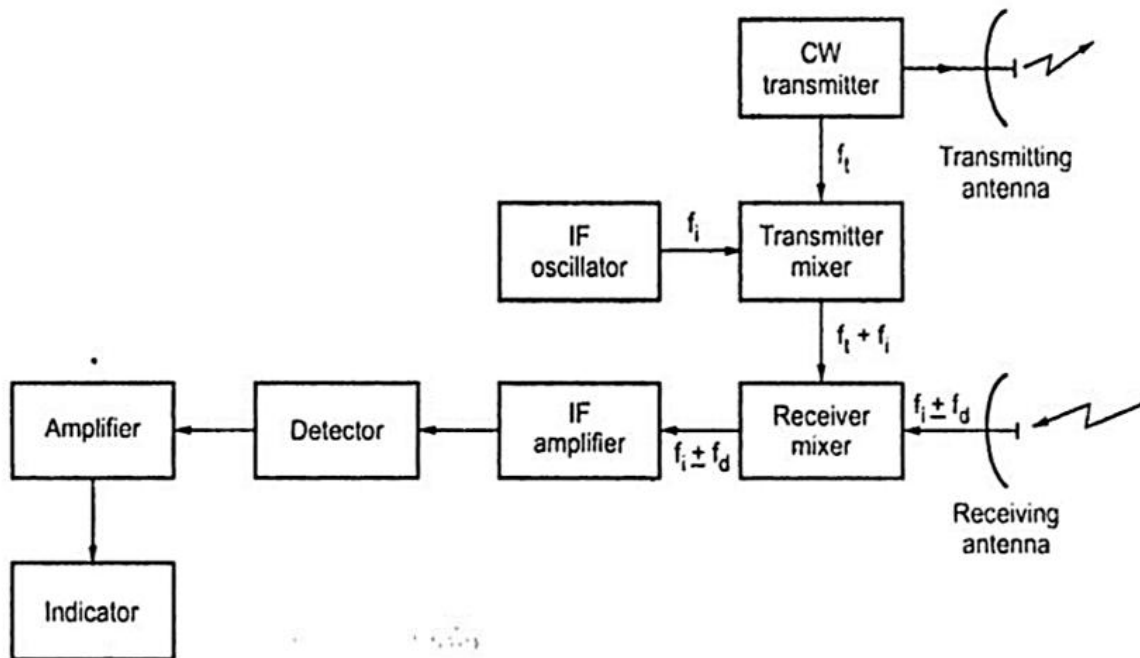

Fig. CW Doppler radar

The block diagram of CW Doppler Radar contains a set of blocks and the **function** of each block is mentioned below.

- **CW Transmitter** – It produces an analog signal having a frequency of  $f_t$ . The output of CW Transmitter is connected to both transmitting Antenna and Transmitter Mixer-I.
- **Local/IF Oscillator** – It produces a signal having a frequency of  $f_i$ . The output of Local Oscillator is connected to Transmitted Mixer-I.
- **Mixer-I** – Mixer can produce both sum and difference of the frequencies that are applied to it. The signals having frequencies of  $f_t$  and  $f_i$  are applied to Mixer-I. So, the Mixer-I will produce the output having frequencies  $f_t+f_i$  or  $f_t-f_i$
- **Receiver Mixer-II** – Mixer can produce both sum and difference of the frequencies that are applied to it. The signals having frequencies of  $f_t+f_i$  and  $f_o \pm f_d$  are applied to receiver Mixer-II. So, the Mixer-II will produce the output having frequencies of  $f_i \pm f_d$ .
- **IF Amplifier** – IF amplifier amplifies the Intermediate Frequency (IF) signal. The IF amplifier shown in the figure allows only the Intermediate Frequency,  $f_i \pm f_d$  and amplifies it.

- **Detector** – It detects the signal, which is having Doppler frequency,  $f_d$
- **Doppler Amplifier** – As the name suggests, Doppler amplifier amplifies the signal, which is having Doppler frequency,  $f_d$
- **Indicator** – It indicates the information related relative velocity and whether the target is inbound or outbound.

### **Advantages :**

- Single frequency transmission and hence narrow receiver bandwidth
- Duty cycle is unity, so mean power can be as high as transmitters will permits.
- Ability to see moving targets in presence of large number of echoes from stationary target to which it is blind.
- Target velocity can be measured using Doppler shift.
- Zero minimum range.
- Simple to design and construct.

### **Disadvantages:**

- No timing marks, so unable to measure range.
- Separate antennas are required for receiver and transmitter.
- Cannot detect targets crossing its beam at right angles

### **Applications:**

- Measurement of the relative velocity of a moving target.
- Human Gait Recognition
- In Doppler Radar.

## Frequency Modulated Continuous Wave Radar:

Simple continuous wave radar devices without frequency modulation have the disadvantage that it cannot determine target range because it lacks the timing mark necessary to allow the system to time accurately the transmit and receive cycle and to convert this into range. A very important type of FMCW radar pulse is the linear FM sweep. In this case, the range to the target is found by detecting the frequency difference between the received and emitted radar signals. The range to the target is proportional to this frequency difference, which is also referred to as the beat frequency.

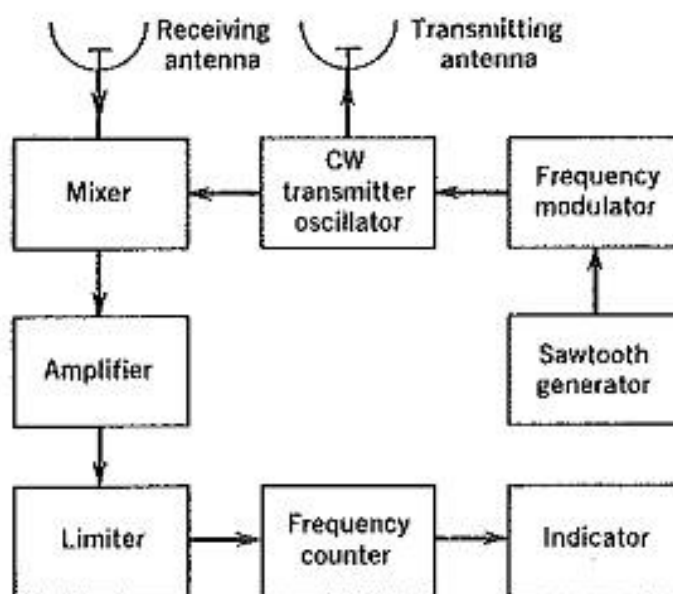
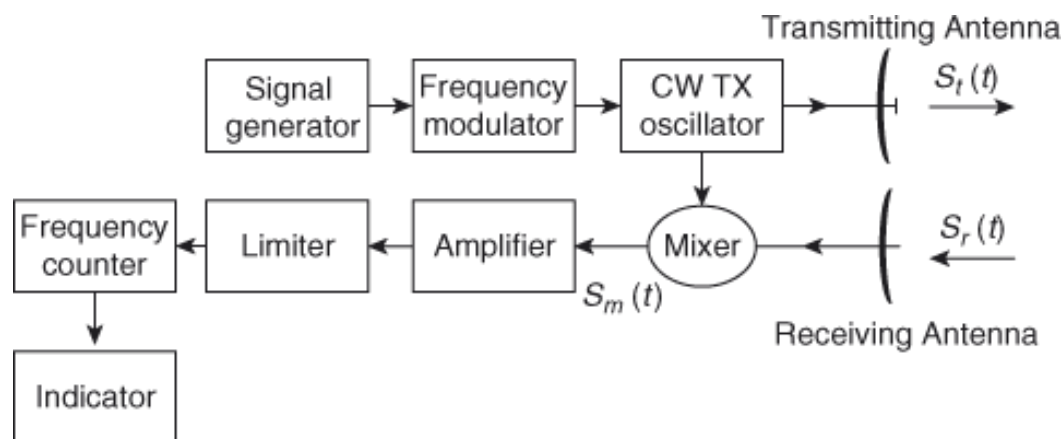

**FIGURE 16-16** Block diagram of simple FM CW radar altimeter.

The sawtooth waveform generated by sawtooth generator is frequency modulated and thus signal after frequency modulation, is transmitted by Transmitter. Portion of transmitted signal acts as reference signal to produce beat frequency. The frequency of transmitted signal increases linearly with increasing amplitude of modulating signal.

The transmitted signal hits at the target and reflects back to a receive antenna. The frequency difference between the received signal and the transmitted signal increases with delay, and the delay is linearly proportional to the range, that is the distance of the target from the radar. The echo from the target is then mixed with the transmitted signal and down-converted to produce a beat signal which is linearly proportional to the target range after demodulation.

- Signal is amplified by the amplifier.
- Limiter is used to remove unwanted amplitude variations .
- Frequency counter and Indicator are used to display the reading.

The figure below shows the transmitted and received ramp signals:

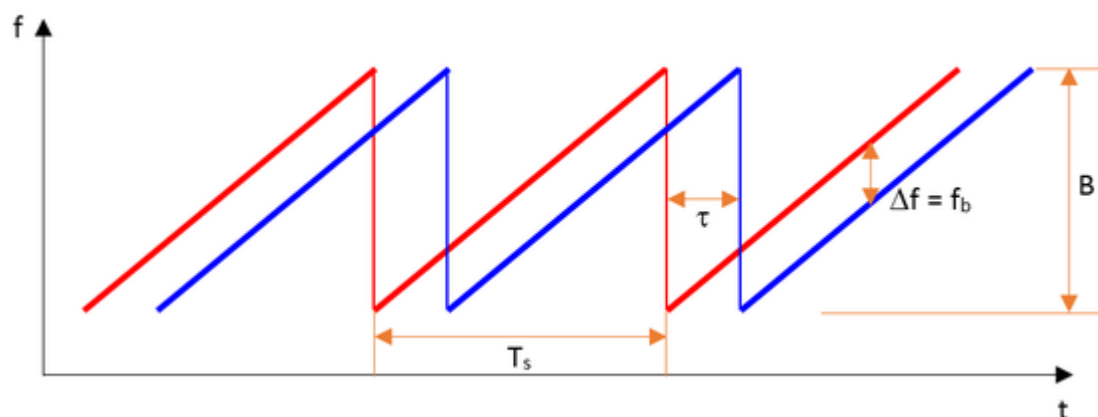

The delay  $\tau$  is equal to the round-trip wave travel time and given by:

$$\tau = 2R / c$$

where  $R$  is the target range and  $c$  is the free-space speed of light. The beat frequency at the output of the receiver is given by:

$$f_b = B \tau / T_s$$

where  $B$  is the total frequency deviation of the chirp signal and  $T_s$  is the sweep time (chirp period). The target range is thus found from the following equation:

$$R = cT_s f_b / 2B$$

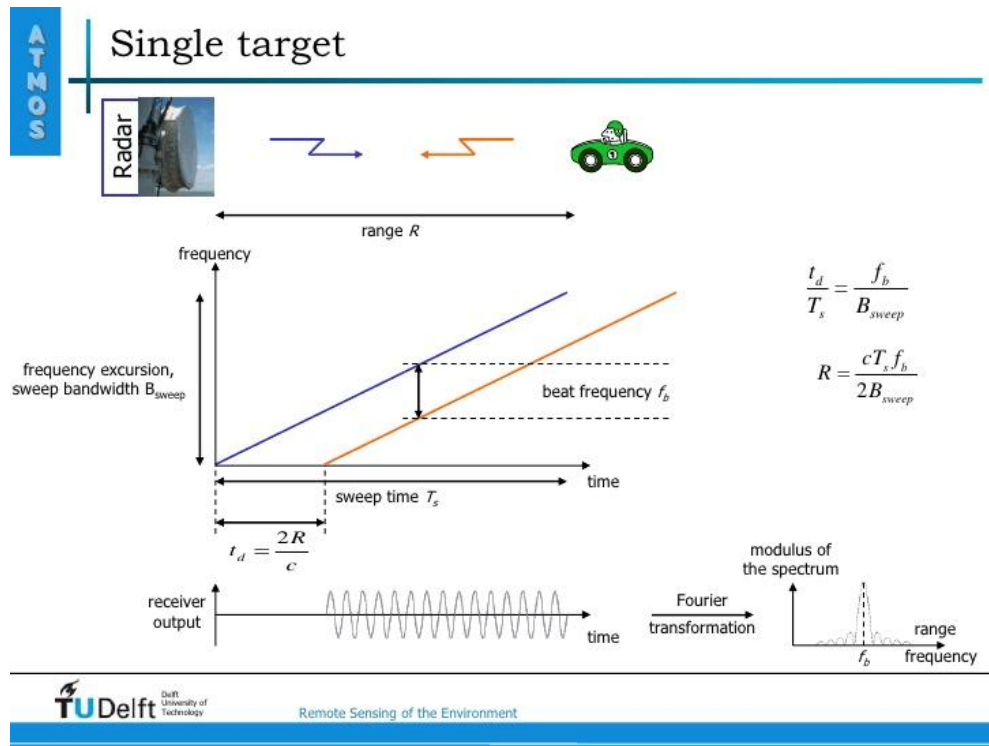

Earth is assumed to be stationary and therefore there is no Doppler frequency shift. However if there is relative velocity between aircraft and earth, a doppler frequency shift is superimposed on FM beat frequency due to Doppler's effect. Even then the range can be computed as the average frequency difference.

## Advantages of FMCW Radar

- High-resolution distance measurement suits well for imaging applications.
- Quick updating of measurement because of continuous transmitting signals.
- Functions well in all types of weather (rain, humidity, fog, and dusty) and atmospheric conditions, because electromagnetic radiations of short wavelength are used.
- Better in detecting tangential motion than Doppler-based systems.

## Disadvantages of FMCW Radar

- Costlier than other competing technologies.
- Radar is most susceptible to interference from other radio devices.
- More computing power is required.
- It can be a disadvantage in defense applications because they can be easily blocked by electronic warfare systems.

## Applications of FMCW Radar

- Used in high accuracy applications where repeatability and reliability are required because FMCW radars provide accurate range measurement.
- In transportation, it is used as automotive collision avoidance radars and marine radars.
- Because of its resistance to dust, steam, heat, these are mostly used in the blast furnace of a steel mill.

**RADAR DISPLAY:** A **radar display** is an electronic device to present radar data to the operator. The radar system transmits pulses or continuous waves of electromagnetic radiation, a small portion of which backscatter off targets (intended or otherwise) and return to the radar system. The receiver converts all received electromagnetic radiation into a continuous electronic analog signal of varying (or oscillating) voltage that can be converted then to a screen display.

## Oscilloscopes

Early radar displays used adapted oscilloscopes with various inputs. An oscilloscope generally receives three *channels* of varying (or oscillating) voltage as input and displays this information on a cathode ray tube. The oscilloscope amplifies the input voltages and sends them into two deflection magnets and to the electron gun producing a spot on the screen. One magnet displaces the spot horizontally, the other vertically, and the input to the gun increases or decreases the brightness of the spot. A bias voltage source for each of the three channels allows the operator to set a zero point. In a radar display, the output signal from the radar receiver is fed into one of three input channels in the oscilloscope. Early displays generally sent this information to either X channel or Y channel to displace the spot on the screen to indicate a return. More modern radars typically used a rotating or otherwise moving antenna to cover a greater area of the sky

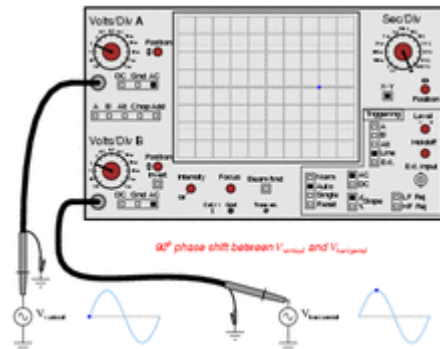

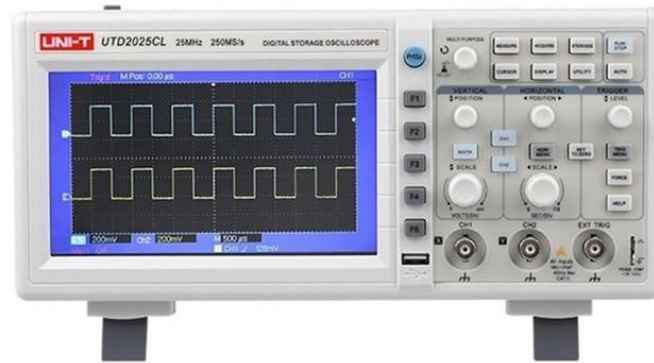

### A-Scope:

The A-scope display, presents only the range to the target and the relative strength of the echo. Such a display is normally used in weapons control radar systems. The bearing and elevation angles are presented as dial or digital readouts that correspond to the actual physical position of the antenna.

It is a two dimensional Radar display. The horizontal and vertical coordinates represent the range and echo amplitude of the target respectively. In A-Scope, the deflection modulation takes place. It is more suitable for **manually tracking Radar**.

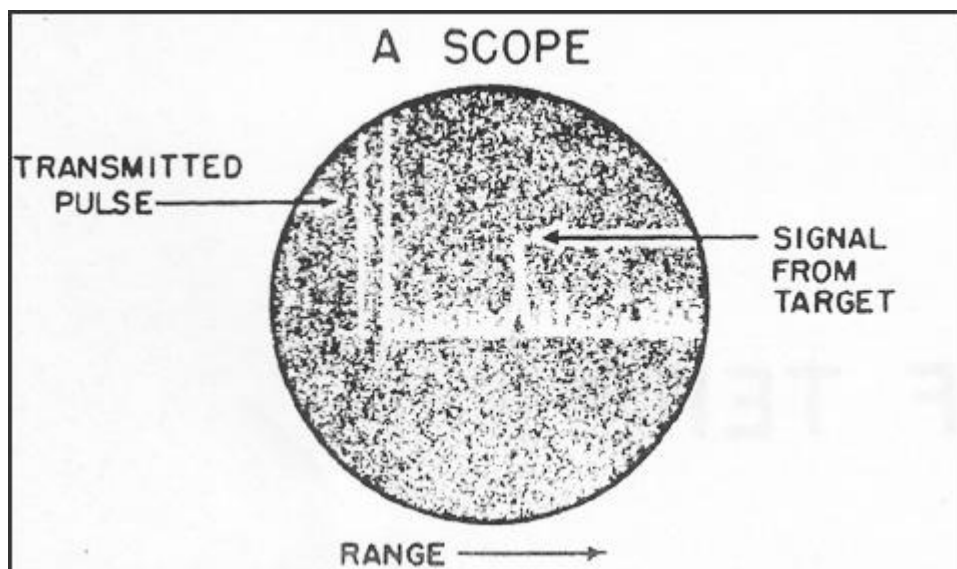

### B-Scope :

It is a two dimensional Radar display. The horizontal and vertical coordinates represent the azimuth angle and the range of the target respectively. In B-

Scope, intensity modulation takes place. It is more suitable for **military Radars**.

### Plane Position Indicator:



The PPI display provides a 2-D "all round" display of the airspace around a radar site. The distance out from the center of the display indicates range, and the angle around the display. It displays the information of echo signal as plan view. Range and azimuth angle are displayed in polar coordinates. Hence, it is called the Plan Position Indicator or the PPI display.

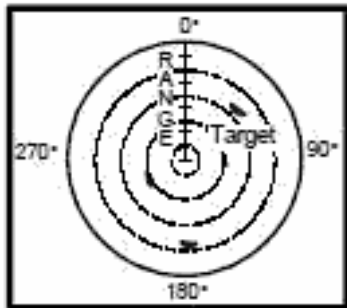

PPI

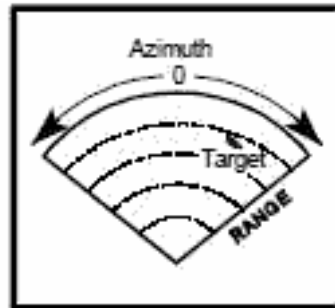

SECTOR PPI

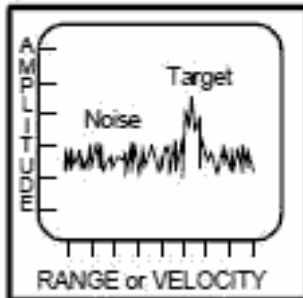

A-SCOPE

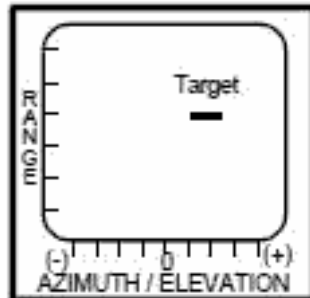

B-SCOPE / E-SCOPE

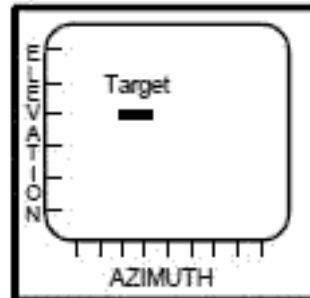

C-SCOPE